

# STYLLIS SERIES BATH

**Oasis**

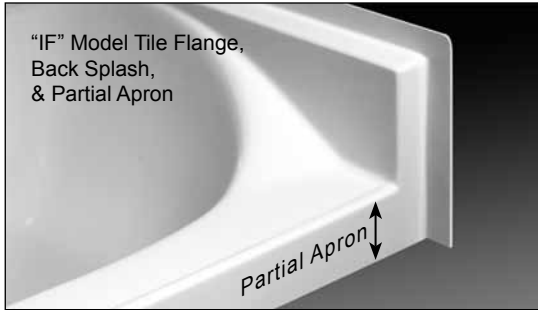

**Home Innovation**  
LAB CERTIFIED™



60-INCH WIDE MODEL

**BA-6036** (Splash & Tile Flange)

**BA-IF-6036** (Splash, Tile Flange, Partial Apron)

Rough-In Dimensions	BA-6036 BA-IF-6036	60" wide x 37-1/4" deep x 25" high (w/ 18-1/4-inch apron)
---------------------	-----------------------	---

Finished Dimensions	BA-6036 BA-IF-6036	60" wide x 36" deep x 23-3/4" high (w/ 18-1/4-inch apron)
---------------------	-----------------------	---

### Unit Features

- Sanitary Grade Polyester Gelcoat Surface
- 2" Dia. RH or LH Drain (see reverse side for location)
- 2-1/2" Dia. Overflow (see reverse side for location)
- "BA" Model: Integral Tile Flange & Full Apron
- "BA-IF" Model: Integral Tile Flange & Partial Apron
- Contoured Neck Rest
- Extra Deep Bathing Sump
- Pre-Leveled Block Base System (IF version)
- Balsa Wood Core Floor Structure
- Textured Floor Pattern

### Special Notes

- Optional ABF Model (provides 3-1/2-inches of drain clearance)
- Whirlpool Systems Available (see reverse side for details)
- UL Listed Whirlpool Systems
- Optional Removable Apron Access Panel

### Unit / System Order Number

Gelcoat:	BA-6036 R/L	BA-IF-6036 R/L
	BA-6036 R/L / ABF	BA-IF-6036 R/L / ABF
	BA-6036 R/L / 6P (Builder System)	BA-IF-6036 R/L / 6P (Builder System)
	BA-6036 R/L / ABF / 6P (Builder System)	BA-IF-6036 R/L / ABF / 6P (Builder System)
	BA-6036 R/L / CWS (Carress System)	BA-IF-6036 R/L / CWS (Carress System)
	BA-6036 R/L / ABF / CWS (Carress System)	BA-IF-6036 R/L / ABF / CWS (Carress System)

### System Trim

Standard 6P & CWS Trim (order code): White trim on White unit (WHT) - Bone trim on Bone unit (BON) - Biscuit trim on Biscuit unit (BSC)

### Order Number / Description

CWS: *Carress System* includes: 4-Adjustable side jets, 4, micro rotating foot jets (stacked), 2-micro pulse back jets, variable flow control, twin air controls, electronic system control, and a 13.5 amp pump/motor.

Options: In-Line Heater (1\*) (order: ILH-STR)  
 Ozone Generator (1\*) (order: OZG)  
 Chromatherapy Pkg (1\*, 2\*) (order: CLT)  
 Water Level Sensor (1\*, 2\*) (order: LWV)  
 Trim Upgrade (1\*)  
 Chrome (order: CWS-CHR)  
 Brushed (Satin) Nickel (order: CWS-SNK)

### Order Number / Description

6P: *Builder System* includes: 6-Adjustable jets, twin air controls, pneumatic system control, and 5.50 amp pump/motor.

Options: In-Line Heater (1\*) (order: ILH)  
 Ozone Generator (1\*) (order: OZG)  
 Removable Apron Access Panel (order: APG-5412)

Notes: (1\*) Factory installed options  
 (2\*) Includes system control upgrade

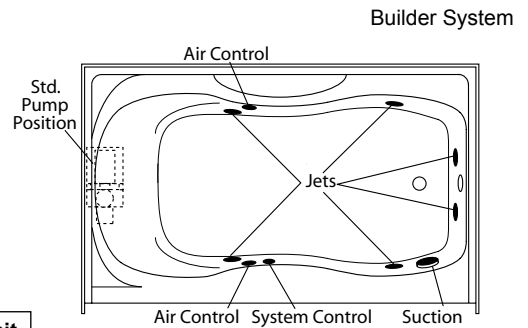
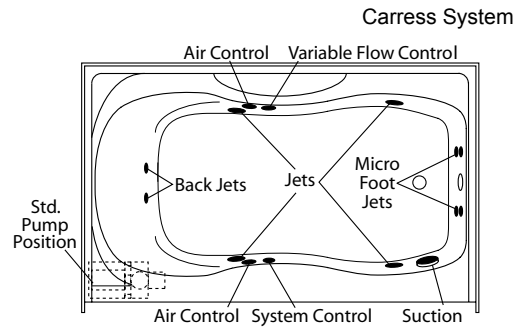
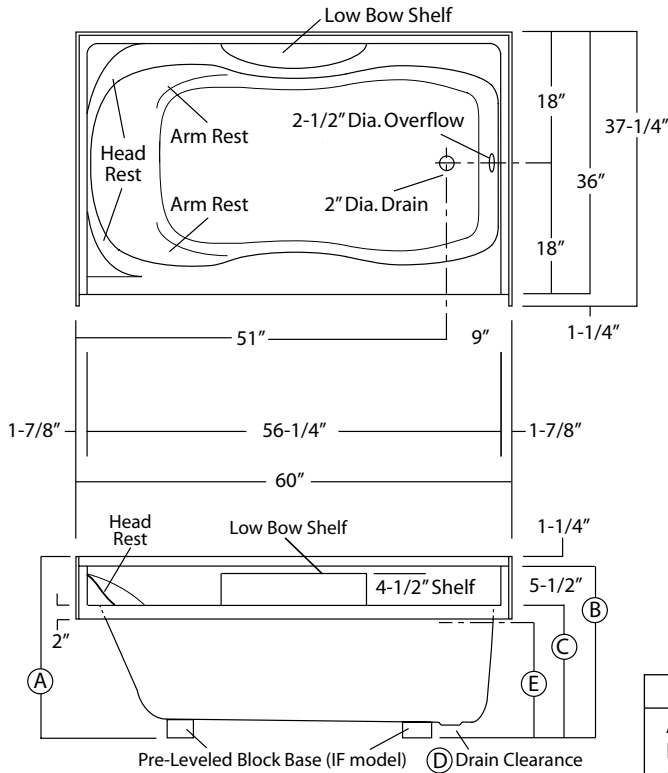

BA-IF-6036R (illustrated)

(full apron extends down to room floor)

Sump Dimensions: 50" long x 23-3/4" wide x 15-3/4" deep

Sump Capacity: 54 gal. (unoccupied - to overflow)

Whirlpool Operating: 35 gal.

Photographic images may include optional components and appear different than actual product.  
 Dimensions shown are maximum. Due to the nature of the materials involved, actual unit dimensions can vary (tolerances: +0 / -3/8 inch).  
 Oasis reserves the right to modify or discontinue product and/or associated equipment without prior written or verbal notification or obligation.